

Hydropump Model RH1400 Installation Instructions

Please read all the instructions before attempting to install the PUMP. The pumping capacity may vary depending on your piping configuration, battery capacity and its age.



Specifications	Physical Size:
Pump Motor: 12 VDC, 21 Amps	Pump Length: 9 1/2" Width: 6" Height: 6"
Battery Charger: 1.0 AH @ 12 VDC, 0.4 Amp Load	Battery case L: 17", W: 9-1/2", H: 11"
Charger Service: 120 VAC, 60 HZ, GFCI Outlet	Pump weight: (without battery): 10 Lb
Float Switch: Vertical Style, with mounting clamp	Total shipping weight: 22 Lbs.
Water Alarm: Integrated	1-1/4" PVC Connection
Battery Requirements: 12 Volt Marine deep cycle or Sealed Lead acid, Size 27	
Battery NOT included (Ask for Highest Quality in Size 27, Best Warranty)	

** Extra battery case available as an add-on kit to double pumping time; not pumping rate

Flow Rates:	Pumping Times:
At 5 feet 1800 Gallons Per Hour	Using Marine Deep Cycle Battery/30 second cycles
At 9 feet 1400 Gallons Per Hour	At 1 minute intervals 12 Hours
Do not exceed 15 feet total lift; pumping capacity will be affected	At 5 minute intervals 48 Hours
	At 15 minute intervals 96 Hours

Included Parts:	Pumping Times:
Motorized Pump Unit with stainless steel mounting bracket	One-Way Foot Valve and suction screen
Battery Case with Cover	PVC Tee Connector with elbow and 2 adapters
Battery Charger with cables	Flexible Discharge Hose: 4 Feet
Vertical Switch to activate pump (pre-wired) and (1) large metal clamp	Rigid PVC Pipe: (1) pieces 19" ; (1) piece 6" Long
(3) Cable ties, (3) Smaller Hose Clamps, (1) 90° PVC Elbow	Installation Instructions; safety specifications

Additional Parts & Supplies Needed:	Tools Needed:
Check valve for primary pump (existing?)	Hand saw and/or PVC cutting tool
PVC Primer and Cement (small cans) for PVC connections	Phillips and slotted screwdrivers
Teflon Tape or Pipe Sealant (Dope) for threaded connections	Utility knife, tape measure, large adjustable pliers
Deep cycle Marine, Lead Acid, Gel, or AGM Battery (Contact us, we have AGM and Gel Batteries)	

 <p>WARNING ELECTRICAL SHOCK HAZARD Disconnect power before installing or servicing this product. A qualified service person must install and service this product according to applicable electrical and plumbing codes.</p>	 <p>WARNING EXPLOSION OR FIRE HAZARD Do not use this product with flammable liquids. Do not install in hazardous locations as defined by National Electrical Code, ANSI/NFPA 70.</p>
<p>Failure to follow these precautions could result in serious injury or death. Replace product immediately if switch cable becomes damaged or severed. Keep these instructions with warranty after installation. This product must be installed in accordance with National Electric Code, ANSI/NFPA 70 so as to prevent moisture from entering or accumulating within boxes, conduit bodies, fittings, float housing, or cable.</p>	

Customer Satisfaction Guarantee and One Year Limited Warranty

Within 30 days of purchase, if you are not completely satisfied with your new PUMP, Base Products Corporation (The Company) will refund your money, in full, excluding shipping charges, as long as product is returned in its original packaging, unused, un-installed, and in re-salable condition, shipping pre-paid. Please contact the dealer where you purchased your pump to obtain refund. If purchased directly from Base Products, you must call our Customer Satisfaction Department at 800 554 1426 to receive return authorization or Technical Assistance. Please give your name, address, phone number, purchase date, and installation address.

The Company warrants this Battery Powered Backup Sump Pump against defects in material and workmanship for One Year from the date of the shipment. In the event of any defect in the pump unit within the warranty period, The Company will, at its option, repair, replace, or recondition the product without charge, providing the product is returned, prepaid to our offices in Buffalo, New York. This shall constitute the exclusive remedy for any alleged defect. The Company shall not be responsible for any incidental, indirect, contingent, or consequential damages, including, without limitation, damages or other costs resulting from labor charges, delays, loss of use, revenue or profit, vandalism, negligence, fouling caused by foreign material, damage from peculiar water conditions, chemicals, electrical problems, or other circumstances over which The Company has no control. The Company makes no other warranties, express or implied, except as provided in this limited warranty. This warranty becomes void by any misapplication, misuse, abuse, or improper installation of the product. This warranty gives you specific legal rights and you may also have other rights which may vary from state to state. Warranty is applicable in the USA and Canada only.

Step by Step Installation

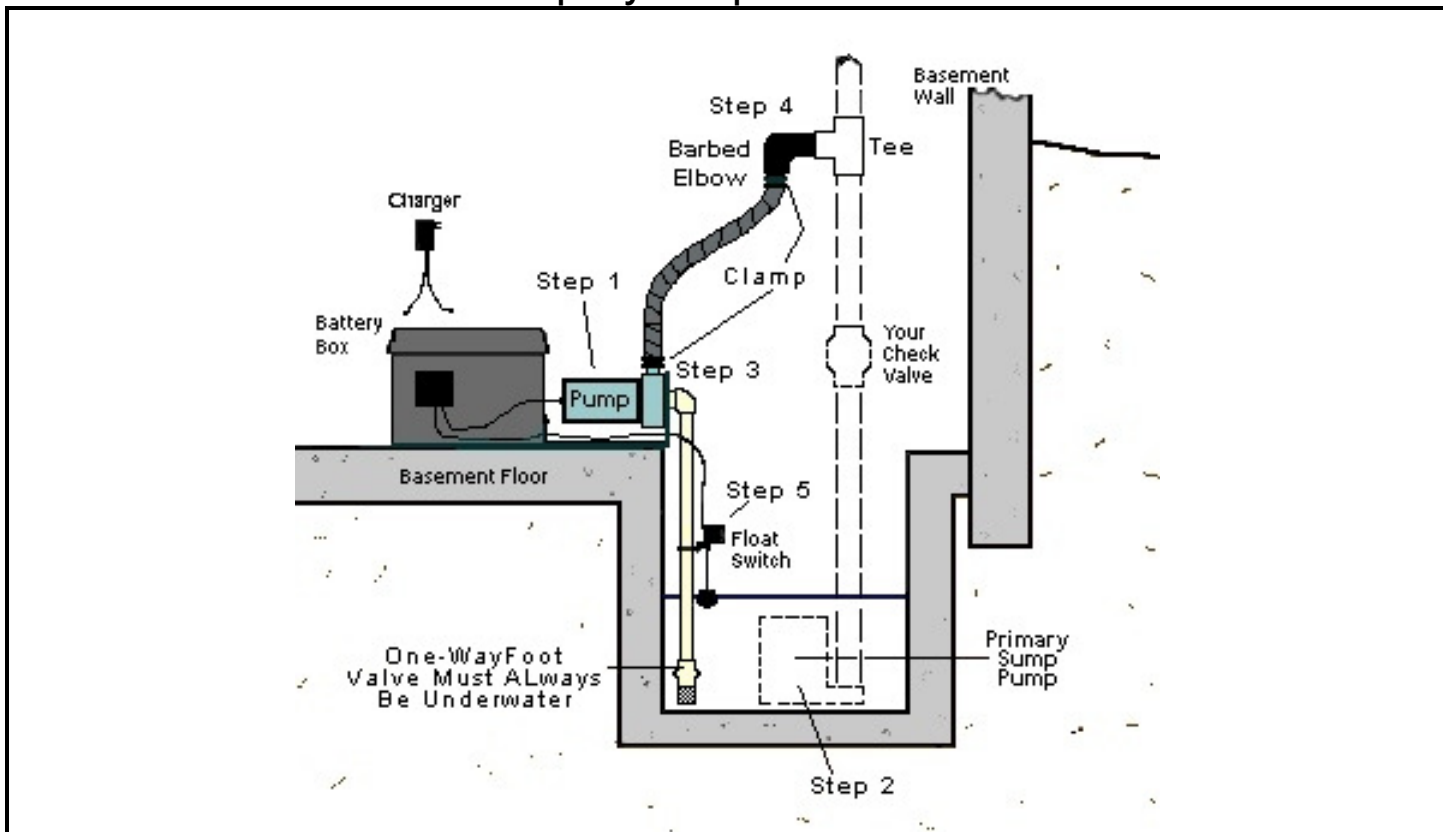

Step by Step Installation

Refer to installation drawing throughout installation.

Step 1 Place PUMP on Floor:

Remove all packaging and materials and hang all wires over the side and out of the battery box. Position battery box and pump in final position on the floor close to the sump pit. Line up the battery box to the plastic corner bracket attached to the rear of the Stainless Steel pump bracket. Use a 1/4" bit and drill a hole into the battery box before placing the battery into it, at the point where it meets the corresponding hole in the corner bracket. Use one #10-32 x 1/2" long Stainless Steel screw and nut provided and attach bracket to battery box to prevent the pump from tipping forward after you complete the installation.

Step 2 Disconnect primary pump:

Unplug primary pump and drain discharge pipe. A high quality, fully functioning check valve **MUST** be present above the main sump pump and below the PUMP discharge connection. Without it PUMP will send water down through your main sump pump and back into the sump. A removable type check valve is recommended in order to service the main sump pump in the future without disconnecting backup PUMP.

Step 3 Install suction pipe:

Prime and cement the foot valve assembly into the end of the 19" long PVC pipe section supplied with PUMP and allow time to dry. Measure the vertical distance from pump inlet fitting to approximately 2 - 4 inches from bottom of sump pit. **[Make sure the water is never PUMPED below the foot valve opening]** Connect 90° elbow, as shown in drawing above and use the 6" long piece of PVC pipe for the horizontal section and push into socket fitting on pump suction inlet. Once all sections are correctly positioned; disassemble, prime, and cement all joints. Allow time to dry. **SUCTION AND DISCHARGE LINE MUST BE FULL OF WATER AT ALL TIMES IN ORDER TO OPERATE. FOOT VALVE IS DESIGNED TO KEEP IT FULL EVEN IF THE SUMP WATER EVAPORATES AWAY.**

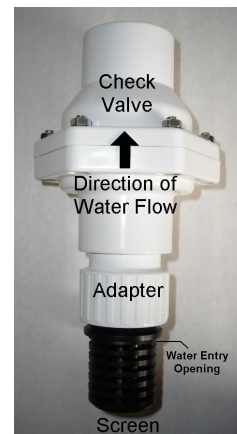

Step 4 Install Discharge:

Assemble the Tee fitting by applying pipe thread sealant onto the threaded end of the black polypro elbow and tighten securely. Use the flexible hose from the pump to the Tee Assembly to help you determine the proper position of the tee above the existing main sump pump check valve. Hose may be cut to fit, if needed, using a utility knife or hack saw. If the main pipe line is 1-1/4" PVC use the white PVC bushing adapters provided and glue into the Tee fitting. If these are unneeded, set them aside. Once you have marked the Tee position, carefully and squarely cut and remove a 2" section from your main pump discharge pipe. Prime, glue, and insert into the desired location one end at a time for best result, allowing time to dry. While drying, you may attach the flexible hose to the pump discharge connection and do the same at the Tee fitting by attaching the hose to the black barbed hose connector. Secure the hose at both ends using the stainless steel hose clamps provided. A third hose clamp (included) may be needed at the connection to the pump. Place them close together and tighten securely.

**Step 5 Float Switch:**

Attach vertical float switch to side of the suction pipe using the larger hose clamp provided. Float should be positioned in its fully down position near the "normal primary pump" level. Slide float up the rod by hand to simulate a normal response to high water and confirm the location of the "high" level. The float will need to rise to the top of the rod to turn the pump on and travel all the way down to the bottom of the rod to turn the pump off. If necessary, you may move the stopper on the rod to a new position for an earlier shut-off. Make sure the pump will come on before the float reaches the top of the pit so water never rises to the floor level. Pump must turn off before the water drops down below the foot valve so air does not enter the system and break the suction prime. After following the start-up procedures below, you may have to make some minor adjustments to the float to assure proper operation. Adjust floats on both pumps, if necessary. **SUCTION AND DISCHARGE LINE MUST BE FULL OF WATER AT ALL TIMES IN ORDER TO OPERATE. DO NOT ALLOW THE MAIN SUMP PUMP TO DRAIN THE WATER BELOW THE WATER ENTRY OPENING OF THE FOOT VALVE OF PUMP. ADJUST FLOAT OR HEIGHT OF PUMP IF NECESSARY TO PREVENT THIS.**

1. Start Up:

Connect **all Red (+) Pos** wires from charger **and** pump motor together to positive (+) battery terminal. Connect **all Black (-) Neg** wires from charger **and** pump motor together to negative (-) battery terminal using wing nuts on terminals. Tighten securely. Plug charger into a GFCI protected wall outlet. Plug primary pump into wall outlet. If unsure about any of this, consult with a licensed electrician. Alligator clips provided for different types of terminals. (See "Separate Instructions")

Note: If connecting an optional second battery using our "Dual Battery Case", all the **Red Wires** go to the **Positive (+) Terminals** and all the **Black Wires** go to the **Negative Terminals**. Connect the proper-colored wire to each terminal of the first battery and "jump" to the matching terminals of the second battery using the wires included with the Dual Battery Case. This keeps the batteries in "parallel" and allows the charger to maintain both batteries.

Important: Fill sump with water from a hose if needed to test for proper installation. Lift **primary sump pump** float by hand and operate the main pump for approximately 10 seconds. Do this 2 or 3 times to sufficiently prime PUMP with sump water and to purge out any trapped air (Do not run it dry). Verify that all joints are sealed. Now unplug primary pump and fill pit with water. You may simulate the rising water by lifting the float by hand, but don't empty the pit and lose the prime. Confirm that the location and position of the PUMP float is correct and moves freely. Raise float to reach the desired "high level" which will begin the pumping before water reaches the top of the sump. Confirm that the float shuts the pump off when returned to the "low level" before water surface is below the bottom of the foot valve. Repair any leaks now during this process. A small drip may develop at the front of the pump over time. This is normal and should not cause any problem. The water should either evaporate or find its way into the sump, harmlessly. A larger leak should not be ignored, however. Tightening the 4 screws on the green base plate may resolve this easily.

******* Don't forget to plug the primary pump back in when you are finished!! *******

2. Water Alarm:

This alarm is activated at the same time that PUMP activates, to let you know there is a high water situation. It will sound each time PUMP runs and turn off at the end of each cycle. There is a wiring connection inside the junction box, which can be disconnected if silent operation is desired. Remove the four screws from the front cover of the small junction box located on the side of the larger battery box and remove the thin, red alarm wire from terminal block to silence alarm. A small slotted screwdriver will be needed for this. Remember that without the alarm connected, you may not realize that the backup PUMP is operating and the main sump pump needs attention.

3. Maintenance Procedures:

3 - 4 times per year lift the PUMP float by hand and confirm pump operation and water removal. Confirm that the float is allowed to move freely and hits no obstacles. Check battery age and charger status lights. The **RED** light means the charger is **powered** from the wall outlet. The **YELLOW** light means it's **charging**. The **GREEN** light means the charger has switched to the "**Float Mode**". Note: It is normal for the charger to switch back and forth between the "Charging" and "Float" modes. This is an automatic charger; no adjustments or maintenance are required. See Separate Charger Instructions for further details.

4. Troubleshooting:

Pump is running but no water is being removed from pit.

- Pump may have lost its prime: Fill the sump with water and run the main sump pump on and off a few times.
- If necessary, open the hose clamp on discharge hose where it is connected to the Wye fitting and pull the hose off the barbed fitting. Pour water into hose till full. This restores a lost prime. Reconnect hose and start pump again.
- Clogged suction or discharge piping: clear obstruction and restart.

Pump is removing low volumes of water.

- Suction or discharge piping may be partially clogged: clear obstruction.
- Excessive discharge pipe length and/or configuration can produce a large pressure drop; accept the lower flow or change the piping layout, direction, length, etc. (See separate discharge connection kit)
- Battery may need charging or replacing. A new battery often needs 24 - 36 hours of charging. If it is more than 3 years old, it is likely to need replacing.
- Check all PVC joints and confirm that they are cemented and leak-tight. Air leaks reduce pumping capacity.

Pump will not turn on or off properly.

- Float must be fully **down for off** and fully **up for on**. Adjust float by hand to each position required to test pump and re-position clamp on suction pipe, or rubber stopper on bottom of float rod, if necessary, to assure proper operation.
- Battery terminals may be connected improperly: correct and tighten securely.

NOTE: SUCTION AND DISCHARGE LINE MUST BE FULL OF WATER AT ALL TIMES IN ORDER TO OPERATE.

THIS IS NOT A SELF-PRIMING PUMP. THE FOOT VALVE AND CONNECTION TO THE MAIN SUMP PUMP DISCHARGE IS DESIGNED TO KEEP THE LINE AND PUMP FULL OF WATER. DO NOT ALLOW PUMP TO PUMP DOWN DRY. SET THE FLOAT SWITCH ON BOTH MAIN AND BACKUP PUMPS TO TURN OFF WHILE THE FOOT VALVE IS STILL SUBMERGED. SUMP WATER EVAPORATING BELOW THE FOOT VALVE SHOULD BE NO PROBLEM. PUMPING BELOW THAT POINT IS A PROBLEM.

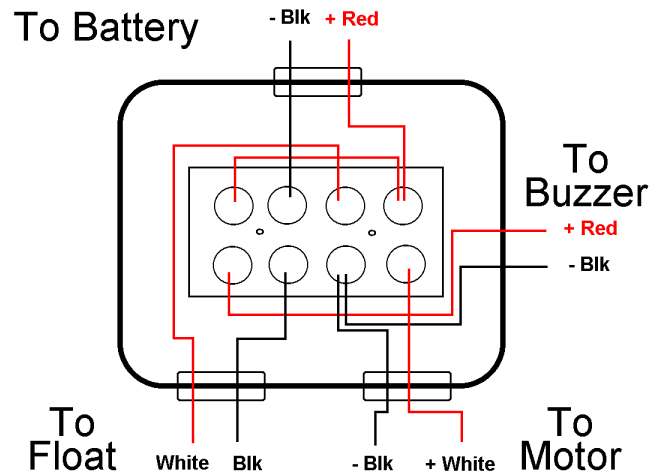

Return Policy

After reading these instructions, should you determine that this product is not suitable for your application, please call The Company or your dealer for return information. Should the pump be installed and you choose to return it, call The Company for return approval. The Company is not responsible for any cost incurred with removal or pump repairs. Proper packaging of the returned product is the customer's responsibility and goods damaged in transit as a result of improper packaging will not be considered for credit.