

Hydropump Model DH900/DH1800 Installation Instructions

Please read all the instructions before attempting to install the PUMP. The pumping capacity of this pump may vary depending on your piping configuration, battery age, and capacity. Remove all packaging and materials from shipping box. Both models install the same; the differences are in size and capacity only, as shown.

Specifications

Pump Motor:	12 Volt DC, DH900: 9 Amps	DH1800: 21 Amps
Battery Charger:	1.0 AH @ 12 VDC, 0.4 Amp Load	
Charger Service:	120 VAC, 60 Hz, GFCI Outlet	
Float Switch:	Tether type with mounting Clamps	
Water Alarm:	Integrated, operated by float	
Battery Requirements:	12 Volt Marine Deep Cycle, Sealed Lead Acid, AGM, or Gel: Size 27	
Battery Not Included	(Ask for highest quality in Size 27, Best Warranty)	

Flow Rates: Gallons / Hour	DH900	DH1800	Pressure:	DH900	DH1800
5 Foot Lift	1,300	2,600		13ft. Max. Lift	25ft. Max. Lift.
9 Foot Lift	900	1,800			

Pumping Times:

DH900: (30 Second Pumping Cycles) **DH1800:** (15 Second Pumping Cycles)

At 1 Minute Intervals	12 Hours
At 5 Minute Intervals	48 Hours
At 15 Minute Intervals	96 Hours

Included Parts:

Motorized Submersible Pump
 Battery Case with Junction Box Attached
 Plug-In Battery Charger
 Stainless Steel Mounting Bracket
 Installation Instructions
 PVC Tee, Check Valve, Adapters, Elbow, Cable Ties, (3) Clamps

Additional Parts & Supplies Needed:

Check Valve for Main Sump Pump
 PVC Primer and Cement
 Thread Sealing Tape or Dope
 12 Volt Marine Battery (See Above)
 4 Foot Discharge Hose, 2 Hose Clamps
 Tether Float with Clamp

⚠ WARNING	ELECTRICAL SHOCK HAZARD Disconnect power before installing or servicing this product. A qualified service person must install and service this product according to applicable electrical and plumbing codes.	⚠ WARNING	EXPLOSION OR FIRE HAZARD Do not use this product with flammable liquids. Do not install in hazardous locations as defined by National Electrical Code, ANSI/NFPA 70.
Failure to follow these precautions could result in serious injury or death. Replace product immediately if switch cable becomes damaged or severed. Keep these instructions with warranty after installation. This product must be installed in accordance with National Electric Code, ANSI/NFPA 70 so as to prevent moisture from entering or accumulating within boxes, conduit bodies, fittings, float housing, or cable.			

30 Day Customer Satisfaction Guarantee and One Year Limited Warranty

Within 30 days of purchase, if you are not completely satisfied with your new PUMP, we will refund your money, in full, excluding shipping charges. Pump must be returned unused and in re-salable condition. Please contact the dealer where you purchased your pump to obtain refund. If purchased directly from Base Products Corporation (The Company), you must call us at 1-800-554-1426 to receive authorization to process return or to receive Technical Assistance. Please give your name, address, phone number, date of purchase, and address of the installation. The Company warrants this Battery Powered Backup Sump Pump against defects in material and workmanship for a period of One Year from the date of purchase. In the event of any defect in the pump unit within the warranty period, The Company will, at its option, replace or recondition the product without charge providing the product is returned, prepaid to our office in Buffalo, New York. This shall constitute the exclusive remedy for any alleged defect. The Company shall not be responsible for any incidental, indirect, contingent, or consequential damages, including, without limitation, damages or other costs resulting from labor charges, delays, loss of use, revenue or profit, vandalism, negligence, fouling caused by foreign material, damage from peculiar water conditions, chemicals, electrical problems, or other circumstances over which The Company has no control. The Company makes no other warranties, express or implied, except as provided in this limited warranty. This warranty becomes void by any misapplication, misuse, abuse, or improper installation of the product. This warranty gives you specific legal rights and you may also have other rights which may vary from state to state. Warranty applicable in the USA and Canada, only.

Step by Step Installation

Refer to installation drawing throughout installation.

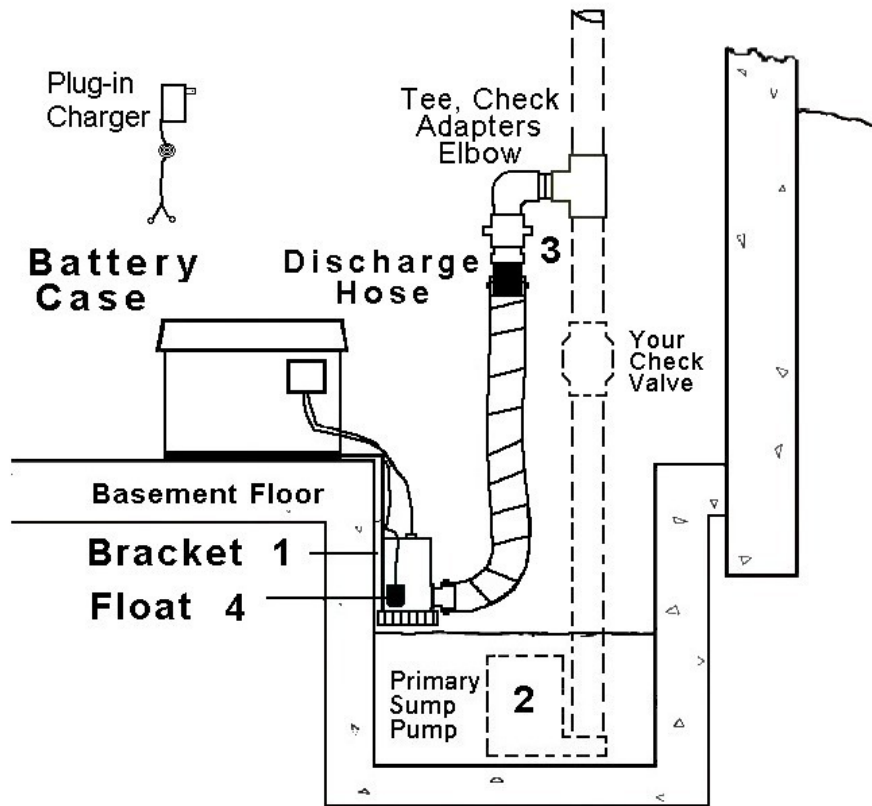

Pumps come with a vent hole at discharge outlet to prevent an air lock.

Step #1 Mount PUMP to bracket:

Place battery into plastic battery case. Do not connect any wires yet. Measure the distance from the basement floor down to the high water level in the sump, determined by the water level at the moment the main pump starts. Then select the proper holes on the 2 brackets and connect using the screws, lock washers, and hex nuts, and tighten securely. This should set the pump to hang just above the water. PUMP motor may be partially below the surface of the water when it reaches its highest normal level. Push one end of flexible discharge hose onto barbed outlet fitting on base of pump and secure with stainless steel hose clamp. Place mounting bracket on floor with pump hanging into the sump as shown and put battery box on mounting bracket to hold securely in place.

Tip: *Twisting the hose in a clockwise (right hand) direction while inserting OR removing makes each process easier.*

Step #2 Disconnect primary pump:

Unplug primary pump and drain water from discharge pipe. A high quality, fully functioning check valve **MUST** be present above the main pump and below the PUMP discharge Tee connection, as shown above. Without it, PUMP will send water back down through your main sump pump which will not pump outdoors, and possibly flood your basement.

Tip: *A flexible coupling type or PVC compression type check valve is recommended to allow you to service the main pump in the future without disconnecting backup PUMP.*

Step # 3 Install Discharge:

- **Indoor Discharge:**

Tee Assembly: The PVC parts are assembled in the bag in their finished position without cement. Prime and cement the check valve and PVC fittings into place. Use Teflon tape on the pipe threads and screw together tightly.

Note: Check valve flow arrow must be pointing upwards.

Using the discharge hose as a guide (which you attached to pump in step #1), determine the position for the finished Tee fitting to be inserted into the main pump discharge pipe.

Mark the position on the main discharge pipe so the PUMP discharge hose will run upward and into the main sump pump discharge pipe without any tight bends or kinks. Cut PVC discharge pipe from the primary pump at the location you marked using a hand saw or PVC cutter. Remove a 2" section of the pipe for insertion of the finished Tee fitting. Prime, glue, and insert into the desired location one end at a time for best result, allowing time to dry. This pipe is usually 1-1/2" PVC; bushings are included if pipe is 1-1/4" PVC.

Tip: *Hose may be cut to fit, using sharp utility knife or hacksaw.*

- **Direct Discharge to Exterior:**

Either pump may also be installed using its own separate discharge to the exterior, if desired. This may be necessary when excessive main discharge piping is present. Use the discharge hose included with the PUMP and add additional hose or pipe as necessary. Refer to the example on the right to run a separate discharge.

Direct Discharge to Exterior

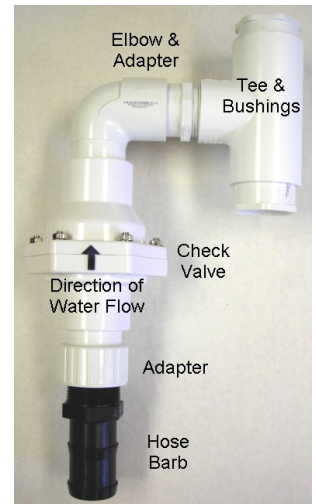
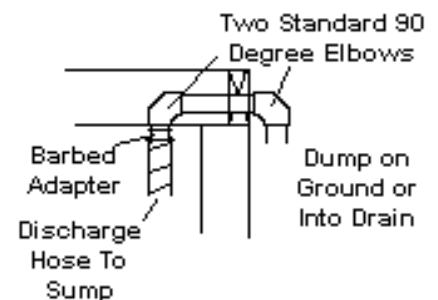
**Step # 4 Float Switch:** 2 Choices available

- **Pump Mounting:**

The float is factory mounted to the correct length. Do not attempt to make the cord longer. (Refer to note below) Should you desire the float in a different position, it can be rotated in either direction.

- **Discharge Pipe Mounting:**

Using the same plastic tether float holder with the smaller hose clamp, secure hose clamp to the primary pump discharge pipe in the proper position above the primary pump. Insert the cord inside the clamp and adjust the length of the cord by pulling or pushing cord through the clamp. When correct position with proper swing is set, tighten clamp securely around cord.

Note: The float switch must turn off the pump before the water level reaches the bottom of the pump suction opening. This will ensure that the pump will not run dry.

**1. Start Up:**

Connect **Red (+) Pos** wires from charger **and** junction box on the side of the battery box and connect securely to positive (+) battery terminal. Connect **Black (-) Neg** wires from charger **and** junction box and connect securely to negative (-) battery terminal (use wing nuts on battery terminals for this). After battery is connected, plug charger into a GFCI protected wall outlet.

Note: If connecting a second battery using our "Dual Battery Case", all the **Red Wires** go to the **Positive (+) Battery Terminals** and all the **Black Wires** go to the **Negative (-) Battery Terminals**. Connect the proper-colored wire to each terminal of the first battery and "jump" to the matching terminals of the second battery using the wires that come with the Dual Battery Case. This keeps the batteries in "parallel" and allows the charger to maintain both batteries. Be sure to keep the cable ends from touching each other while connected to the battery, or they will short circuit and may cause harm to the system or even cause injury.

Important: Fill sump with water from a hose if needed to test for proper installation. You may simulate the rising water by lifting the float by hand (never run either pump dry). Confirm that the location and position of the PUMP and float are correct and float moves freely. Raise float to reach the desired "high level" so pumping begins before water reaches the top of the sump (Best if also below the inflow pipes). Confirm that the float shuts the pump off when returned to the "low level" while water surface still covers the PUMP intake. Do not allow it to pull air or it will damage the pump. Repair any leaks now during this process. A hole is drilled near pump outlet to prevent airlock.

Battery charging: Refer to charger instructions for more information about operation and the light indicators.

******* Don't forget to plug the primary pump back in when you are finished!! *******

2. Water Alarm:

This alarm is activated at the same time that PUMP activates, to let you know there is a high water situation. It will sound each time PUMP runs and turn off at the end of each cycle. Remember, not all sump pump failures are the result of power failures; this alarm may be your only way of knowing something is going on with your sump pump. There is a wiring connection inside the junction box on the side of the large battery case, which can be disconnected if quieter operation is desired. Remove the four screws from the small junction box cover and remove the thin, red alarm wire from terminal block to silence alarm.

3. Maintenance Procedures:

Every 2-3 months, lift the PUMP float by hand and confirm pump operation and water removal. Confirm that the float is allowed to move freely and hits no obstacles. Check battery age and charger status lights. This charger is automatic; no adjustments or maintenance are required. Follow battery manufacturer's recommendations and procedures for maintenance of each battery. Do not mix different types of batteries when using two of them.

4. Troubleshooting:

Pump is running but little or no water is being removed from pit.

- **Jammed impeller-** Make sure impeller is spinning freely & not blocked by debris.
- **Clogged discharge:** clear obstruction and restart.
- Pump may be **air-locked**. Clear vent hole.
- **Excessive discharge** length or configuration can produce a pressure drop; accept the lower flow or change the layout, direction, length, etc.
- **Battery may need charging** or replacing. A new battery often needs 24 - 36 hours of charging. If it is more than 3 years old, it may need replacing.

Pump will not turn on or off properly.

- Float must be **down for off** and **up for on** and operates within a 90 degree swing cycle at 45 and 135. Adjust float to test pump and adjust position and length of swing to assure proper operation within pumping range.
- Battery terminals may be connected improperly: correct and tighten securely. Red to Positive; Black to Negative.

Pump won't run at all.

- Check battery connections and all wires to be sure all are secure. Check battery condition.

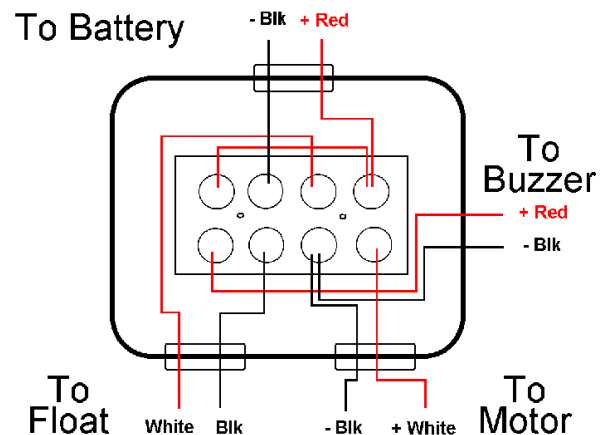

Return Policy

After reading these instructions, should you determine that this product is not suitable for your application, please call The Company or your dealer for return information. Should the pump be installed and you choose to return it, call The Company for return approval. The Company is not responsible for any cost incurred with removal or pump repairs. Proper packaging of the returned product is the customer's responsibility and goods damaged in transit as a result of improper packaging will not be considered for credit.